

# Model T5220 Electro-Pneumatic I/P, E/P Transducer

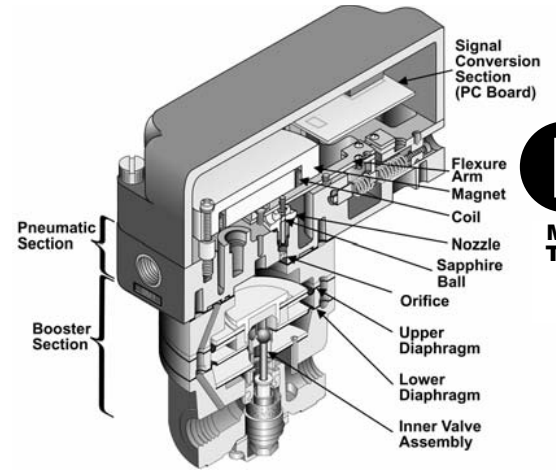

## Features

- Fast Response to Input Signal changes results in faster loop control and savings in process materials.
- Integrated Volume Booster Output meets input requirements of final control elements requiring a higher capacity output signal and/or increased output pressure.
- Six Input Signal Ranges meet most process and machine requirements.
- Negative Bias Option allows zero pressure based operation.
- Five Booster Ratios meet industrial equipment requirements for higher output pressure ranges.
- Temperature Compensation provides stable operation under environmental changes.
- Vibration Resistance maintains set points under adverse vibration conditions.
- Various Mounting Configurations allow installation flexibility for most applications.
- NEMA 3R or optional NEMA 4X Enclosure for outdoor and indoor installations.
- Conduit Port for convenient wiring.



**B**

**Model T5220**

**INSTRUMENTS • CONTROLS • VALVES**  
 CLICK TO VISIT OUR WEBSITE  
**ARCO** Engineering, Inc. SINCE 1954  
 3317 Gilmore Industrial Blvd.  
 Louisville, KY 40213  
 Ph: (502) 966-3134  
 Fx: (502) 966-3135  
 www.arcoengineering.com

## Operating Principles

The T5220 Transducer is an electro-pneumatic device that converts a DC current or voltage input signal to a proportional pneumatic output. This device is made up of two sections, the Signal Conversion Section and the Pneumatic Section.

The Signal Conversion Section (PC Board) accepts a DC current or voltage. This signal is applied to a coil which creates a magnetic force that moves a Flexure Arm.

The Pneumatic Section operates as a force balance system. A Sapphire Ball floats inside a Nozzle and controls the output pressure by exhausting air supplied through an Orifice. This Sapphire Ball acts as a piston exerting a force which is balanced against the force transferred to the Flexure Arm by the Coil.

The Booster Section amplifies the output pressure of the transducer. At set point, the force due to transducer output pressure acting on the top of the Upper Diaphragm is balanced by the force due to booster output pressure acting on the underside of the Lower Diaphragm.

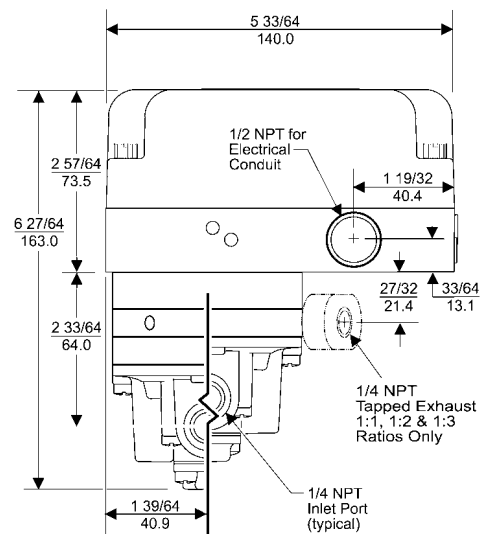
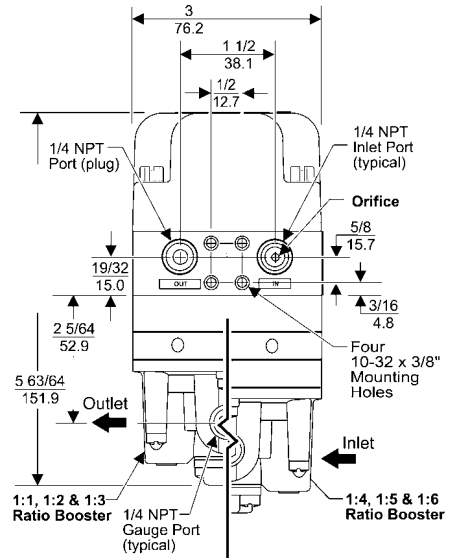

# Model T5220 Electro-Pneumatic I/P, E/P Transducer

**B**  
Model  
T5220

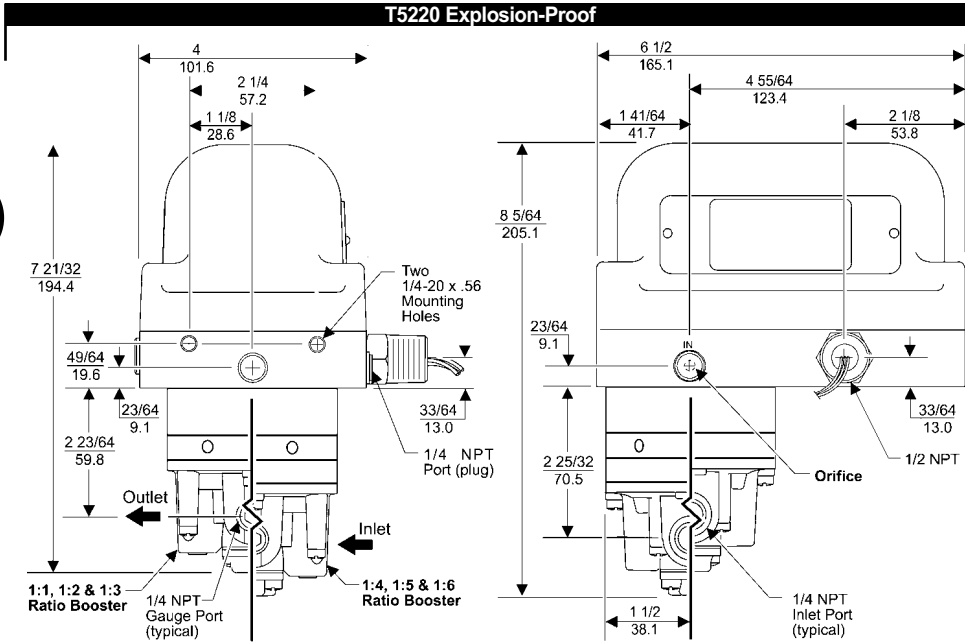

## Hazardous Area Specifications

	Explosion-Proof	Intrinsically Safe										
Factory Mutual (FM) Approvals	<b>TFXPD5220</b> Class I, Division 1, Groups B, C and D; Class II, Division 1, Groups E, F, and G; Maximum Ambient 65° C.	<b>TFI5220</b> Class I, Division 1, Groups A, B, C, and D; Class II, Division 1, Groups E, F, and G; Class III, Division 1, Fibers; NEMA 3R Enclosure. <b>(Upright Position ONLY)</b>										
	<b>TFXPDI5220</b> Class I, Division 1, Groups A, B, C, and D; Class II, Division 1, Groups E, F, and G; Class III, Division 1, Fibers; NEMA 3R Enclosure. <b>(Upright Position ONLY)</b>	<table border="1"> <thead> <tr> <th colspan="2">Entity Parameters</th> </tr> </thead> <tbody> <tr> <td>Voc<sup>1</sup> = 40 VDC</td> <td>Ca<sup>3</sup> = 0 µF</td> </tr> <tr> <td>Isc<sup>2</sup> = 125 mA</td> <td>La<sup>4</sup> = 0 mH</td> </tr> <tr> <td><sup>1</sup>Voc = Open Circuit Voltage</td> <td><sup>3</sup>Ca = External Capacitance</td> </tr> <tr> <td><sup>2</sup>Isc = Short Circuit Voltage</td> <td><sup>4</sup>La = External Inductance</td> </tr> </tbody> </table>	Entity Parameters		Voc <sup>1</sup> = 40 VDC	Ca <sup>3</sup> = 0 µF	Isc <sup>2</sup> = 125 mA	La <sup>4</sup> = 0 mH	<sup>1</sup> Voc = Open Circuit Voltage	<sup>3</sup> Ca = External Capacitance	<sup>2</sup> Isc = Short Circuit Voltage	<sup>4</sup> La = External Inductance
	Entity Parameters											
Voc <sup>1</sup> = 40 VDC	Ca <sup>3</sup> = 0 µF											
Isc <sup>2</sup> = 125 mA	La <sup>4</sup> = 0 mH											
<sup>1</sup> Voc = Open Circuit Voltage	<sup>3</sup> Ca = External Capacitance											
<sup>2</sup> Isc = Short Circuit Voltage	<sup>4</sup> La = External Inductance											
<b>TFN5220</b> NEMA 4X Enclosure.												
Canadian Standards Association (CSA) Approvals		<b>TCI5220</b> Class I, Division 1, Groups A, B, C, and D; Class II, Division 1, Groups E, F, and G; Type 3 Enclosure; Rated 1-5 mA, 4-20 mA, 10-50 mA, 1-5 VDC, 1-9 VDC; Temperature Code T4A.										
		<table border="1"> <tr> <td> <b>Approvals are valid when connected through a Shunt Zener Diode Safety Barrier meeting the following parametric requirements:</b>                       Rated: 28V Maximum 300 Ohm Minimum                 </td> </tr> </table>	<b>Approvals are valid when connected through a Shunt Zener Diode Safety Barrier meeting the following parametric requirements:</b>  Rated: 28V Maximum 300 Ohm Minimum									
<b>Approvals are valid when connected through a Shunt Zener Diode Safety Barrier meeting the following parametric requirements:</b>  Rated: 28V Maximum 300 Ohm Minimum												



## Mounting Kits

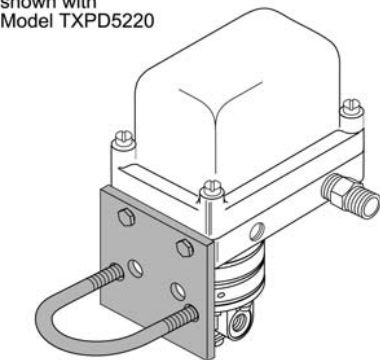
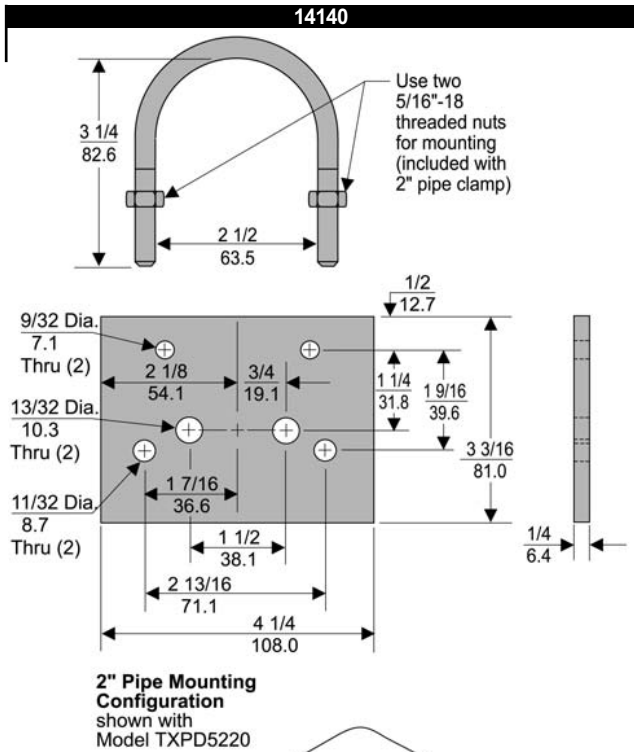

**Mounting Kit 14140**  
Includes the following:  
Mounting Plate • 2" Pipe Clamp  
Support Bar • Two 1/4" Lockwashers  
Two 1/4-20 x 5/8" Bolts • Two 3/8" Lockwashers  
Two 3/8-16 Nuts • Two 3/8-16 x 1/2" Caps

## Model T5220 Transducer Kits & Accessories

- Mounting Bracket Kits.....14140 (sold separately)  
15268 (sold separately)  
14596 (sold separately)

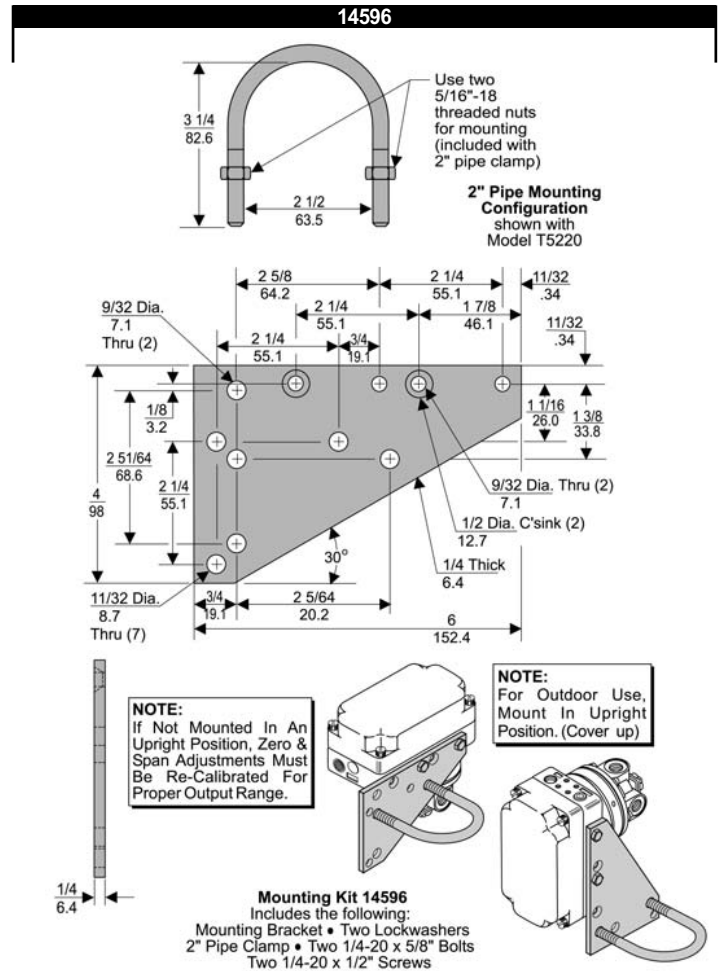
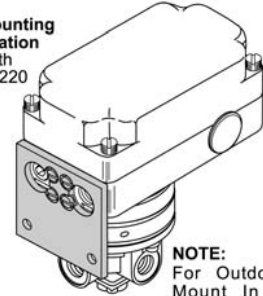
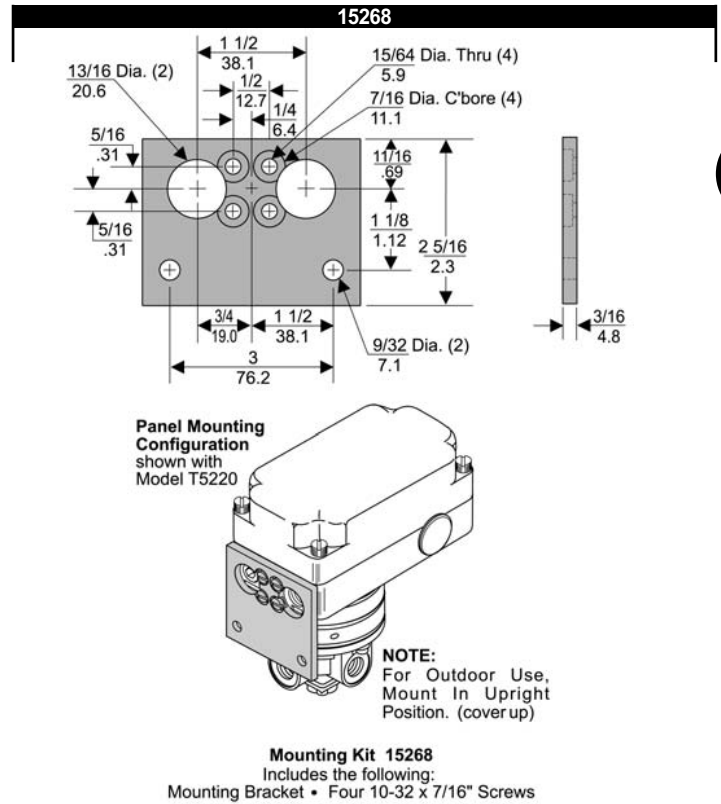

**Model  
T5220**

## Specifications

### Supply Pressure<sup>1</sup>

20 + 2 psig, [1.5 + 0.15 BAR], (150 + 15 kPa)

### Output Capacity (SCFM)

15 (25.5 m<sup>3</sup>/HR) Max. @ 20 psig, [1.5 BAR], (150 kPa) supply. 45 (76.5 m<sup>3</sup>/HR) @ 100 psig, [7.0 BAR], (700 kPa) (with separate supply.)

### Exhaust Capacity (SCFM)

7 (11.9 m<sup>3</sup>/HR) downstream pressure @ 5 psig, [.35 BAR], (35 kPa) above 3 psig, [0.2 BAR], (20 kPa) set point.  
14 (23.8 m<sup>3</sup>/HR) downstream pressure @ 5 psig, [.35 BAR], (35 kPa) above 15 psig, [1.0 BAR], (100 kPa) set point.

### Air Consumption (SCFM)

0.28 (0.48 m<sup>3</sup>/HR) Max. (dead end) @ 20 psig, [1.5 BAR], (150 kPa) supply

### Output Range (1:1 Ratio)

3-15 psig, [0.2-1.0 BAR], (20-100 kPa)

### Supply Pressure Effect

+ 0.3% of Span for a 1 psig, [0.07 BAR], (7 kPa) supply change between 18-22 psig, [1.2-14.5 BAR], (120-145 kPa).

### Shock & Vibration Effect

Negligible up to 2 g's between 5 Hz and 200 Hz

### Terminal Based Linearity

+ 0.50% Full Scale (T5220 only), within 0.6% Output Span (T5222-T5226)

### Independent Linearity

within 0.25% Full Scale (T5220 only), within 0.3% Output Span (T5222-T5226)

### Hysteresis & Repeatability

within 0.1% Full Scale (T5220 only), within 0.1% Times Ratio of Output Span (T5222-T5226)

Impedence / Input Signal	Range	OHMS (nominal)
	1-5 mA	2000
	4-20 mA	120 <sup>2</sup>
	10-50 mA	50 <sup>2</sup>
	1-5 VDC	375
	0-6 VDC	375 <sup>3</sup>
	0-12 VDC	2550 <sup>3</sup>
	1-9 VDC	2550

### Ambient Temperature

-40° F to +150° F, (-40° C to +65.5° C)

### Temperature Coefficient

Less than 1% of Span / 50° F (10° C)

### Materials of Construction

Body and Housing . . . . . Aluminum  
Ball and Orifice . . . . . Sapphire, Brass  
Nozzle . . . . . Stainless Steel

## Pressure Ranges

Ratio	Standard Output			Negative Bias Output (B) Option		
	psig	[BAR]	(kPa)	psig	[BAR]	(kPa)
1:1 <sup>1</sup>	3-15	[0.2-1.0]	(20-100)	0-12	[0-0.8]	(0-80)
1:2 <sup>2</sup>	6-30	[0.3-2.0]	(30-200)	0-24	[0-1.5]	(0-150)
1:3 <sup>2</sup>	9-45	[0.6-3.0]	(60-300)	0-36	[0-2.5]	(0-250)
1:4 <sup>2</sup>	12-60	[0.9-4.0]	(90-400)	0-48	[0-3.0]	(0-300)
1:5 <sup>2</sup>	15-75	[1.0-5.0]	(100-500)	0-60	[0-4.0]	(0-400)
1:6 <sup>2</sup>	18-90	[1.2-6.0]	(120-600)	0-72	[0-5.0]	(0-500)

<sup>1</sup> Standard unit is configured for common supply to transducer and booster.

<sup>2</sup> Units require 20 psig, [1.5 BAR], (150 kPa) for transducer and a separate supply for booster. A common supply of up to 110 psig, [7.7 BAR], (770 kPa) can be used provided the prefix Z147 is added to the original order, and the supply pressure is noted.

## Catalog Information

**Catalog Number** T             **522**            

**Underwriting Group**  
Factory Mutual . . . . . F  
Canadian Standard . . . . . C

**Approval Class**  
Explosion-Proof<sup>1</sup> . . . . . XPD  
NEMA 4X/IP65<sup>1</sup> . . . . . N  
None (leave blank) . . . . .     
Intrinsically Safe<sup>2</sup> . . . . . I  
None (leave blank) . . . . .   

**Options**  
Negative Bias- 3 psig, [0.2 BAR], (20 kPa) . . . . . B  
High Option<sup>3</sup> . . . . . HI

**Booster Ratio<sup>4</sup>**  
1:1 (standard) . . . . . 0  
1:2 . . . . . 2  
1:3 . . . . . 3  
1:4 . . . . . 4  
1:5 . . . . . 5  
1:6 . . . . . 6

**Input**  
1-5 mA . . . . . 1  
4-20 mA . . . . . 4  
10-50 mA<sup>5</sup> . . . . .     
1-5 VDC . . . . . 5  
0-6 VDC<sup>6</sup> . . . . . 6  
0-12 VDC<sup>6</sup> . . . . . 8  
1-9 VDC . . . . . 9

**Output**  
psig . . . . . 0  
[BAR] . . . . . 1  
(kPa) . . . . . 2

**Options**  
Tapped Exhaust - 1:1, 1:2, or 1:3 Ratios Only . . . . . E

- <sup>1</sup> Factory Mutual Approval Only.
- <sup>2</sup> Intrinsically Safe Units cannot be set for Reverse Acting Mode in field.
- <sup>3</sup> If high flow (SCFM) is required for the standard 1:1 ratio, select HI Option. Separate supply is required.
- <sup>4</sup> Refer to Table 1. for Pressure Ranges
- <sup>5</sup> Units shipped calibrated 4-20 mA; 10-50 mA units must be calibrated in field.
- <sup>6</sup> Not approved for intrinsically safe ratings.

## Installation

For Installation Instructions, refer to the *Fairchild T5220 Series Electro-Pneumatic Transducer Installation, Operation & Maintenance Instructions*, IS-500T5220.